



MARINE DIESEL ENGINES



FNM HPE 300

| | |
|-------------------------------------|---|
| Configuration | 4 stroke cycle diesel, DOHC 16 V with timing chain |
| Maximum output at crankshaft | 217kW/ 295 hp at 4000 rpm/min. |
| Maximum torque | 560 Nm @ 2400 rpm/min. |
| Displacement | 2.998 cc. |
| Bore x stroke | 95,8 x 104 mm |
| Cylinders | 4, in line |
| Combustion system | Direct Injection Common Rail |
| Aspiration | Supercharged |
| Starting system | Electric starting 12 V – 2,1 Kw |
| Alternator | 14 V – 110° |
| Cooling system | Double water cooling system with heat exchanger |
| Lubrication system | Totally enclosed, forced lubricating system with pump |
| Max. mounting inclination | 15° |
| Dry weight without gearbox | 320 kg |
| Environmental | RCD 2003/44/CE ed EPA TIER 2 |
| Engine mounting | Rubber type anti-vibration mounting |

Power according ISO 8665, tolerance 5%, Diesel fuel according

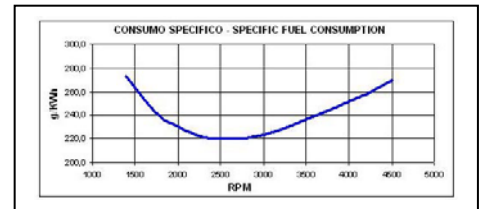
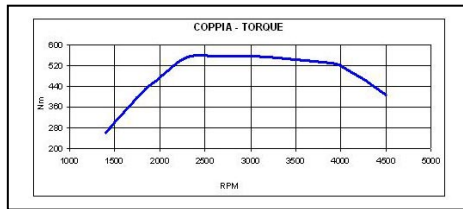
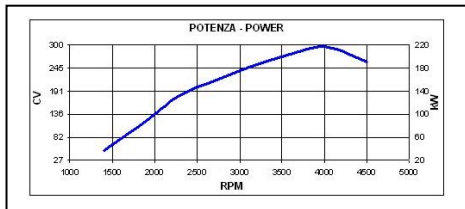

Dimensions (For detailed line-drawings, please refer to our website www.fnm-marine.com or contact your supplier)

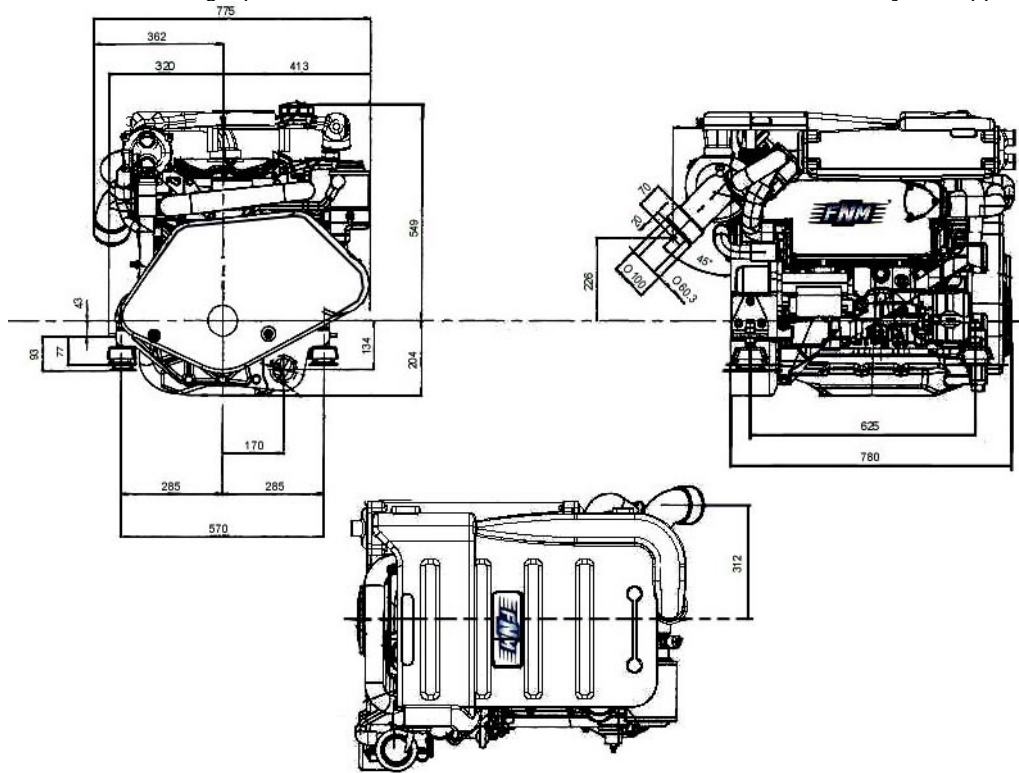

FNM HPE 300

Instrument Panel:

- Oil Pressure
- Water temperature
- Voltmeter
- Rpm Counter
- 8 meter cable

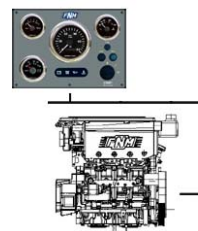

Accessories:

Standard Package

- Gearbox
- Set of flexible mounts
- Alternator 14 V – 110 A with built-in regulator
- Starter motor 12 V – 2,6 kW
- Oil and fuel filters

- Stainless steel seawater-cooled elbow
- Racor filters
- Instrument panel with 8 mt. cable
- Bronze seawater pump
- Engine cover
- Water-cooled exhaust manifold

Optional

- Kit for boat internal heating
- 8 mt. auxiliary extension cable

- Flybridge instrument panel mt. 8
- Trolling valve
- 2-groove front pulley

Text and illustration are not binding. CMD, owner of the FNM brand, reserves the right to introduce adaptations without prior notification. Eng. Vers. 08/09/2010

Compliant with the RCD 2003/44/CE and EPA Tier 2 emission standards.